

Panel thickness 15 max.

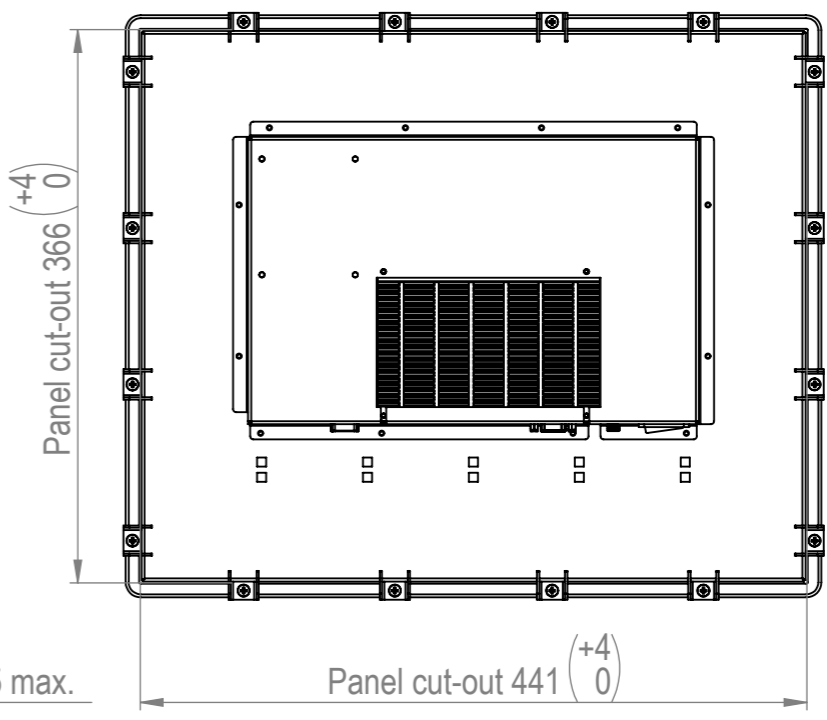

Panel cut-out 366 (+4/0)

Panel cut-out 441 (+4/0)

2.54mm pitch for external power button

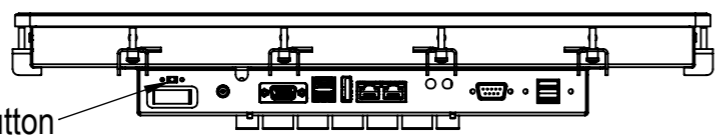

DATE		31-8-2023		DO NOT SCALE DRAWING		DIMENSIONS ARE IN MM	
REV.	DRAWN	FB		<b>TFT/Solutions</b>			
3	APPROVED	FB					
MATERIAL				DESCRIPTION			
				Assembly			
FINISH				PAGE NAME			
				S190-C4, Celeron J6412			
				DWG NO.		A3	
				S190-00			
				SCALE:1:5		SHEET 1 OF 3	

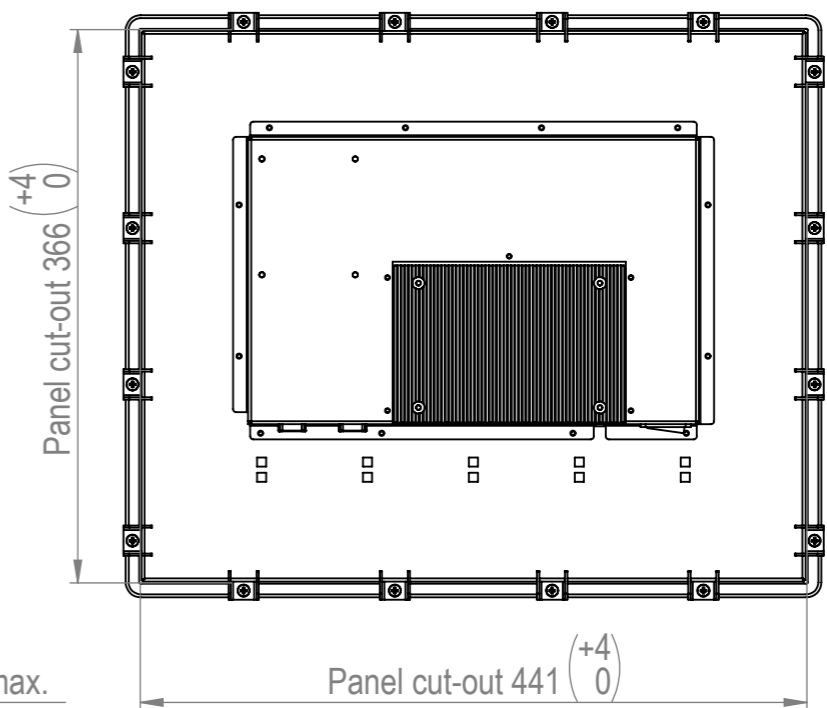
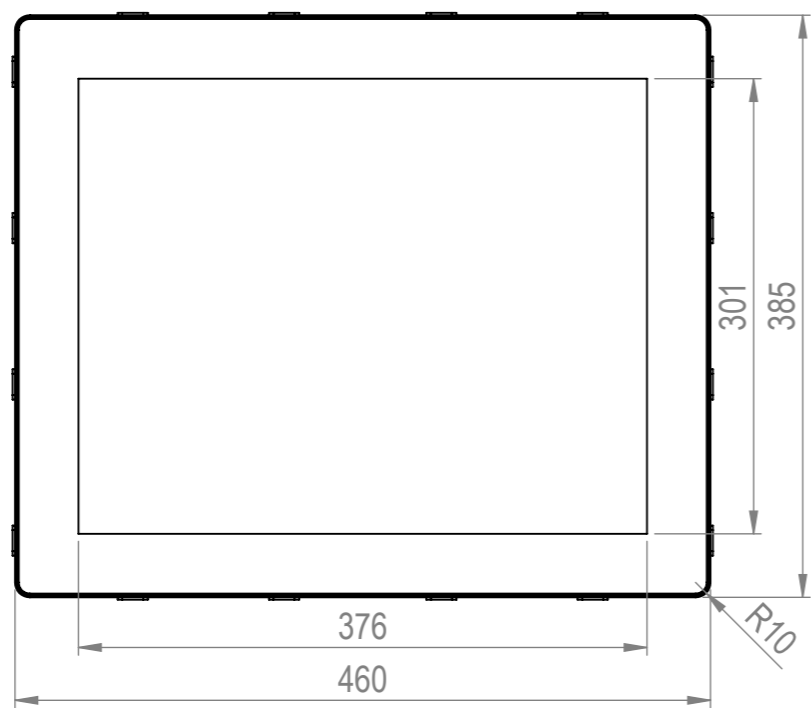
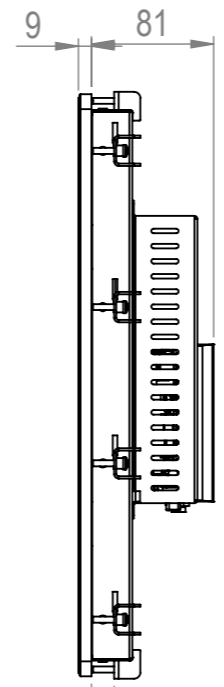
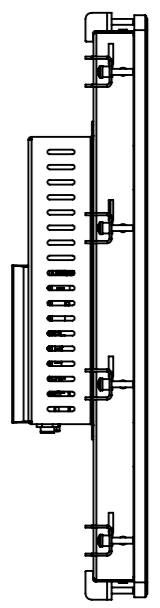
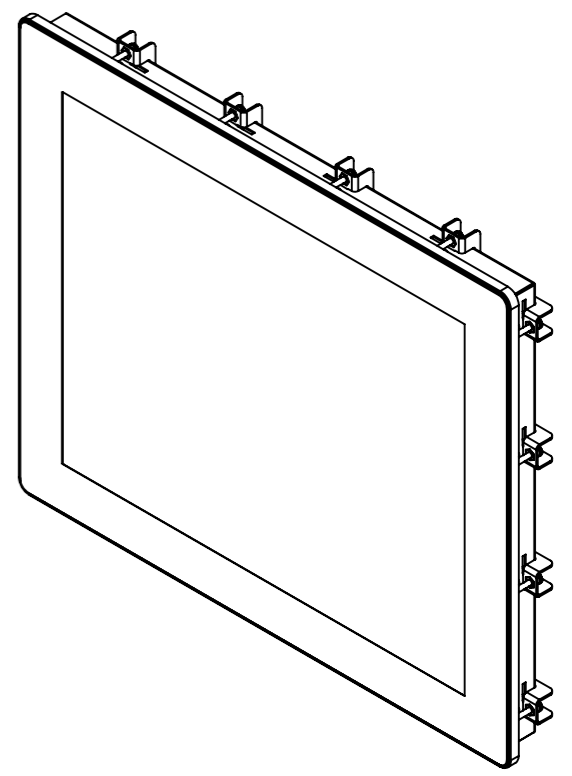
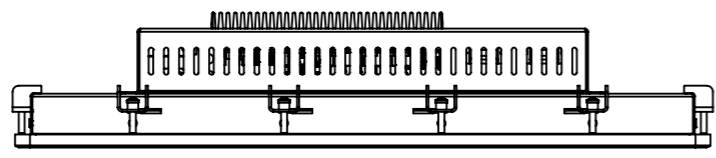

2.54mm pitch for external power button

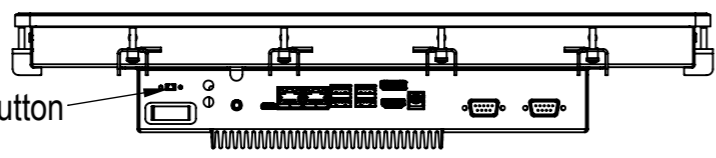

DATE		31-8-2023		DO NOT SCALE DRAWING		DIMENSIONS ARE IN MM	
REV.	DRAWN	FB		<b>TFT/Solutions</b>			
3	APPROVED	FB					
MATERIAL				DESCRIPTION			
				Assembly			
FINISH				PAGE NAME			
				S190-51, i5-8265U			
				DWG NO.		A3	
				S190-00			
				SCALE:1:5		SHEET 2 OF 3	

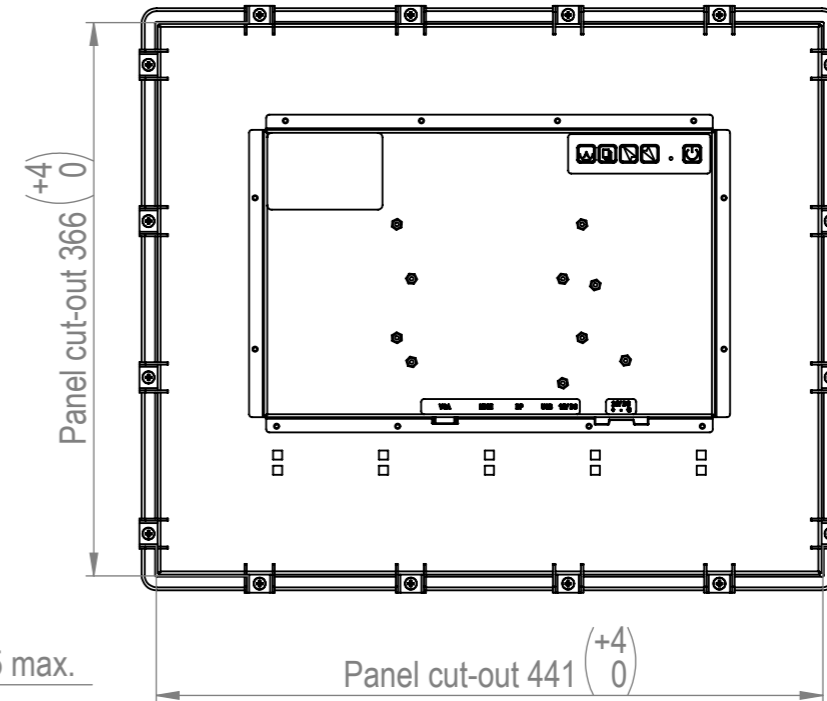
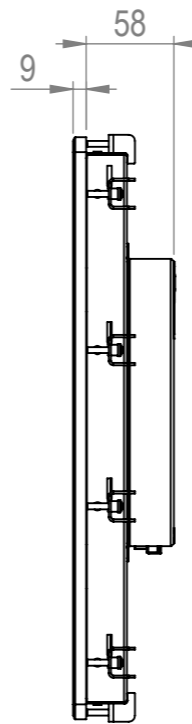
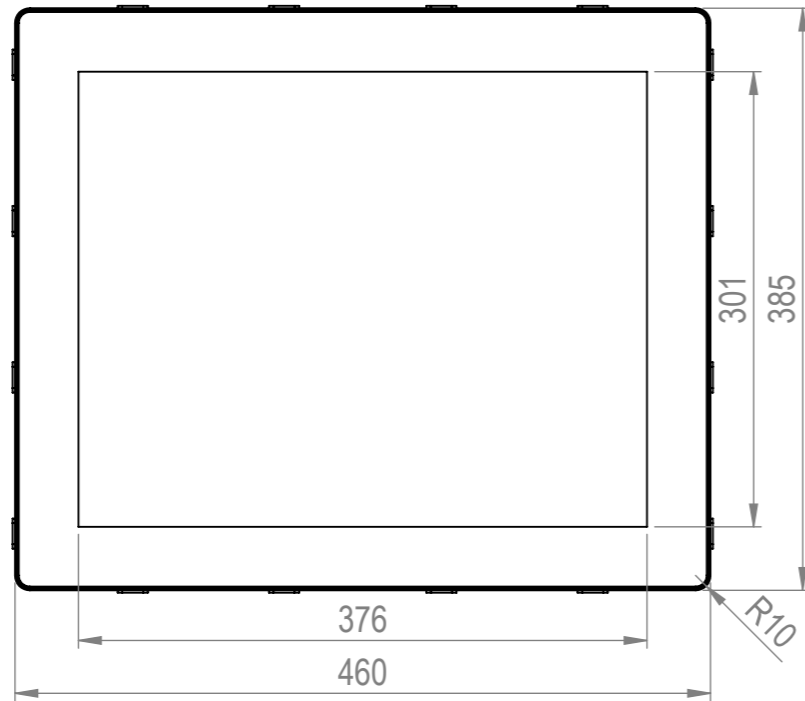
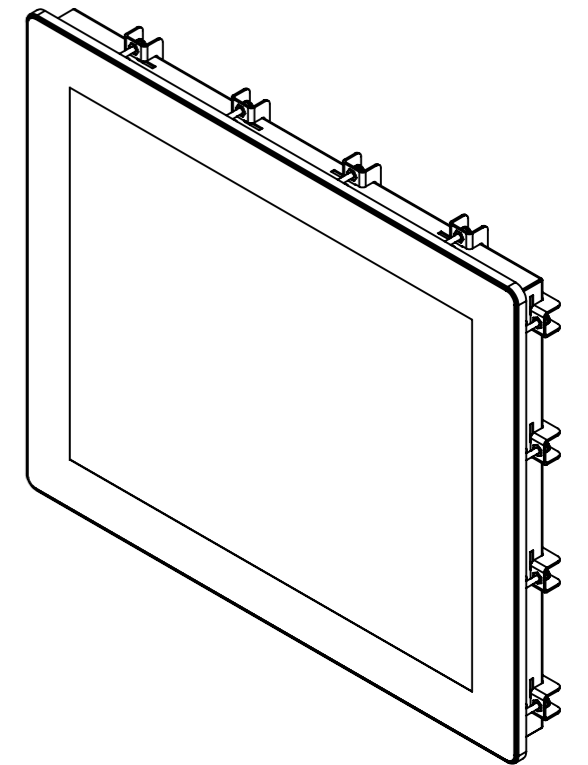
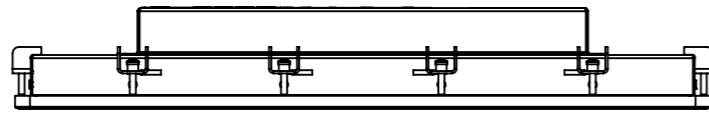

Optional 24V DC input

DATE		31-8-2023		DO NOT SCALE DRAWING		DIMENSIONS ARE IN MM	
REV.	DRAWN	FB		<b>TFT/Solutions</b>			
3	APPROVED	FB					
MATERIAL				DESCRIPTION			
				Assembly			
FINISH				PAGE NAME			
				S190-MON			
				DWG NO.			
				S190-00			
				SCALE:1:5		SHEET 3 OF 3	
						A3	