

SEE LAST SHEET FOR RECOMMENDED PANEL CUT-OUT AND MOUNTING POSITIONS

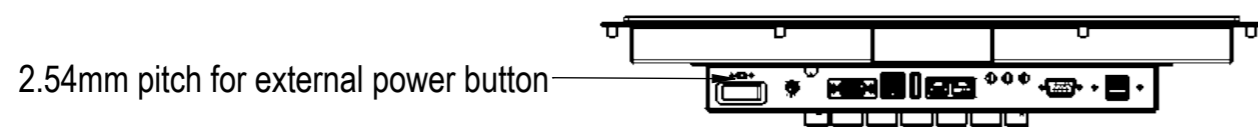

DATE		8-9-2023		DO NOT SCALE DRAWING		DIMENSIONS ARE IN MM	
REV.	DRAWN	AdJ		<b>TFT/Solutions</b>			
1-01	APPROVED	AdJ					
MATERIAL				DESCRIPTION			
				Assembly			
FINISH				PAGE NAME			
				P190-C4, Celeron J6412			
				DWG NO.			A3
				P190-00			
				SCALE:1:5		SHEET 1 OF 4	

SEE LAST SHEET FOR RECOMMENDED PANEL CUT-OUT AND MOUNTING POSITIONS

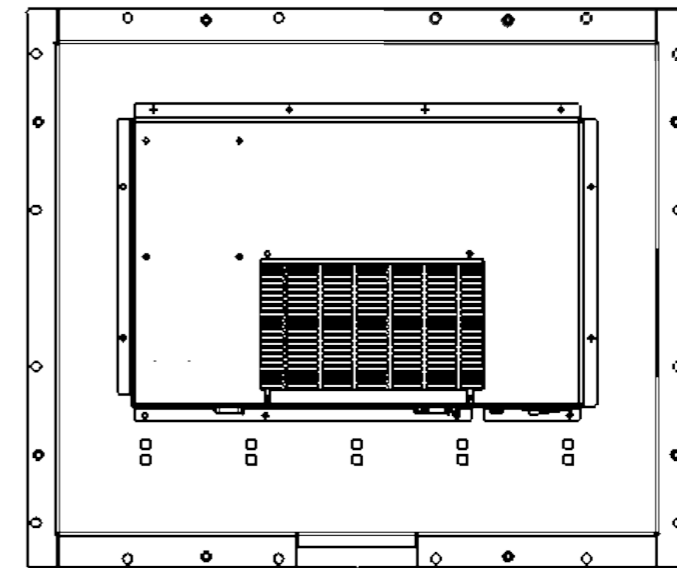
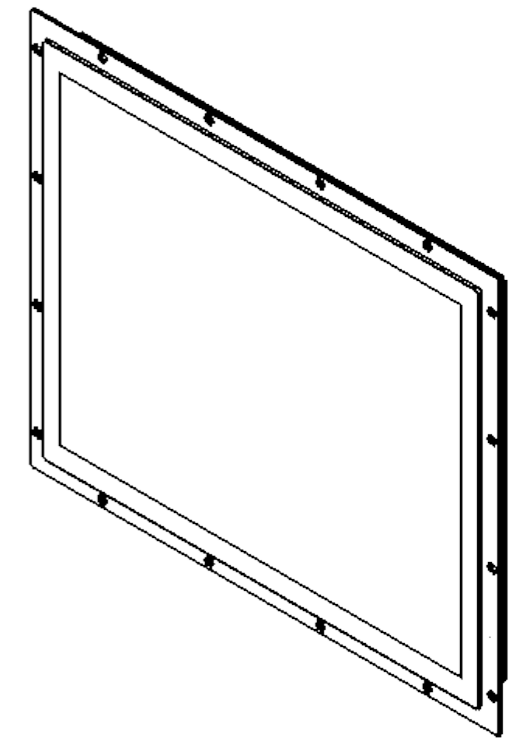
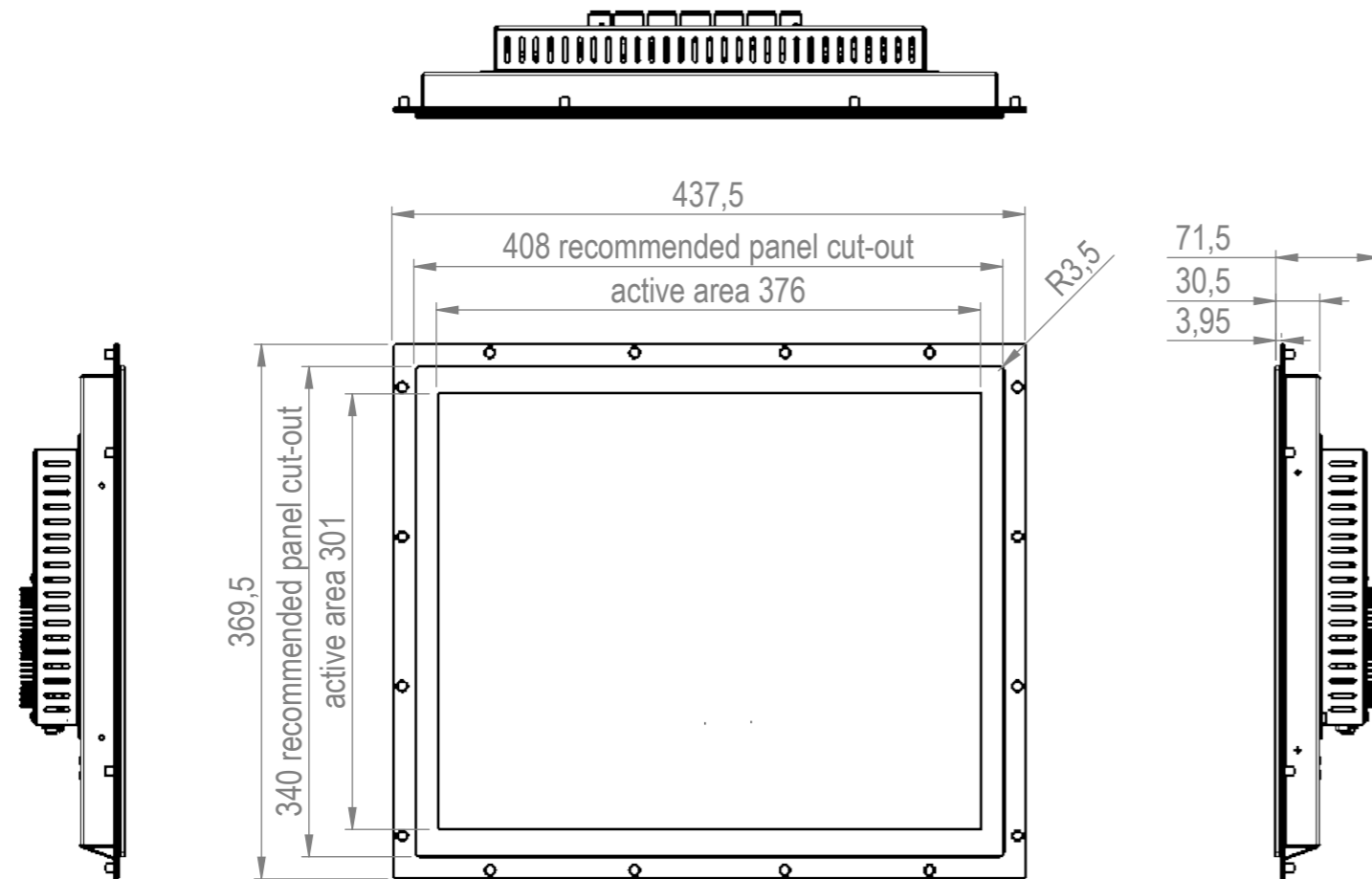
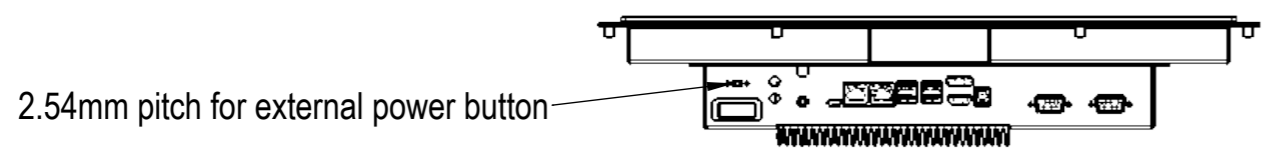
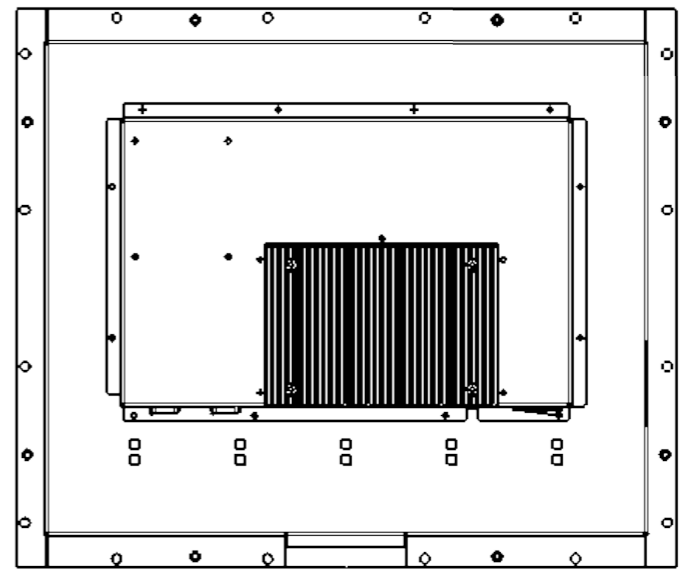
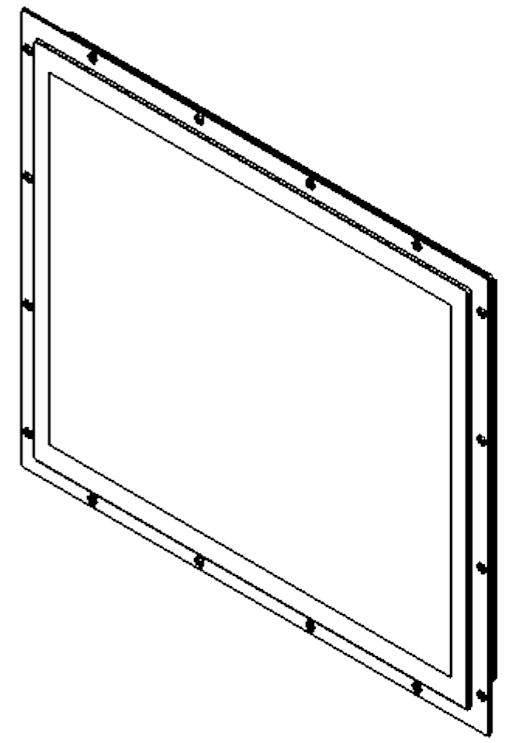
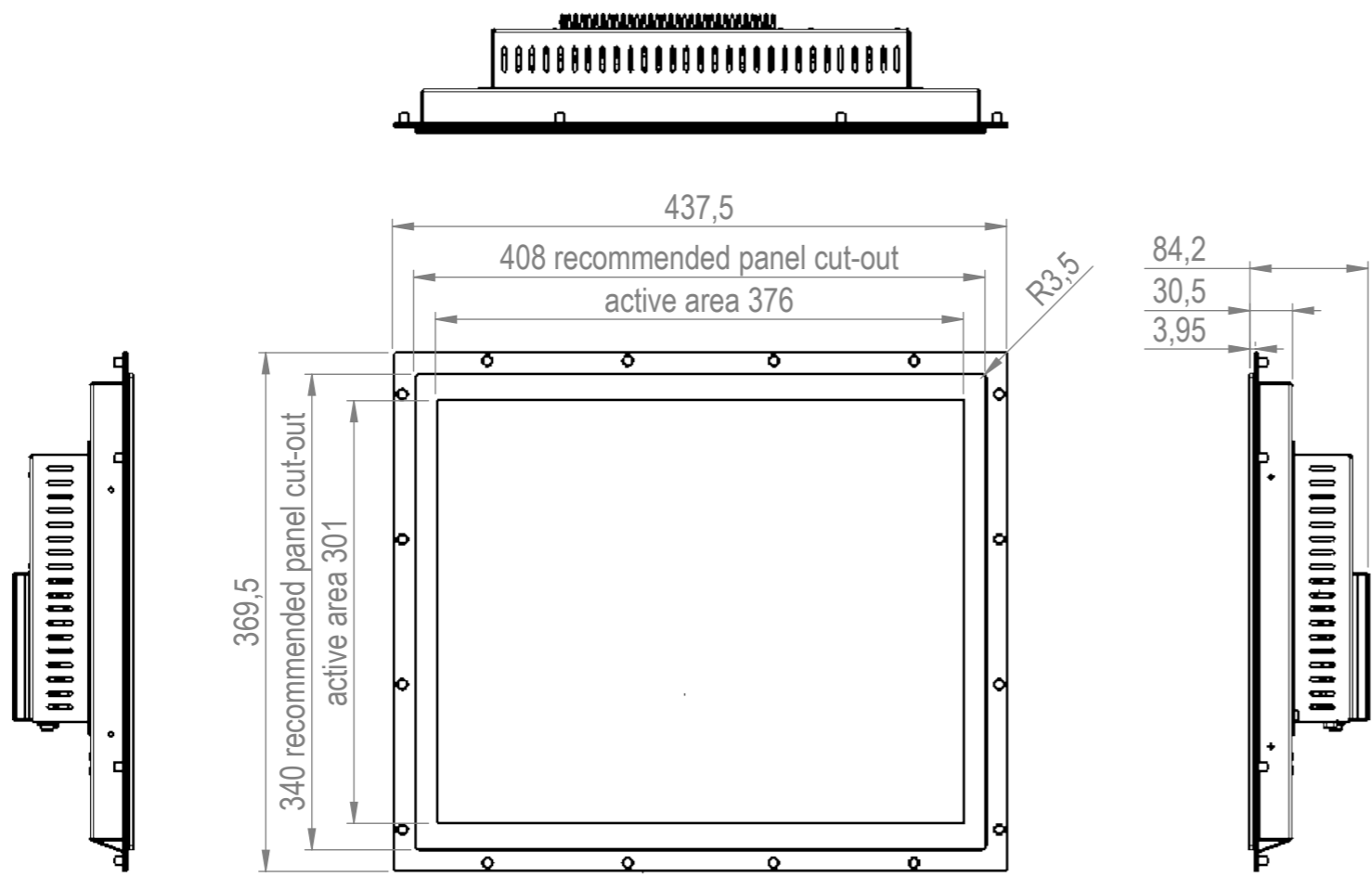

DATE		8-9-2023		DO NOT SCALE DRAWING		DIMENSIONS ARE IN MM	
REV.	DRAWN	AdJ		<b>TFT/Solutions</b>			
1-01	APPROVED	AdJ					
MATERIAL				DESCRIPTION			
				Assembly			
FINISH				PAGE NAME			
				P190-51, i5-8265U			
				DWG NO.			A3
				P190-00			
				SCALE:1:5		SHEET 2 OF 4	

SEE LAST SHEET FOR RECOMMENDED PANEL CUT-OUT AND MOUNTING POSITIONS

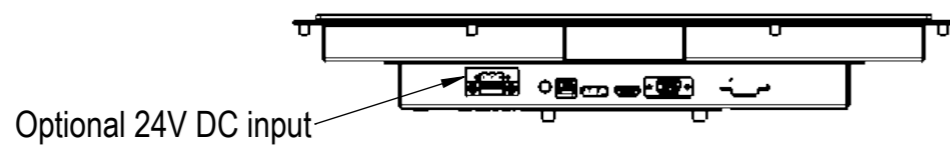
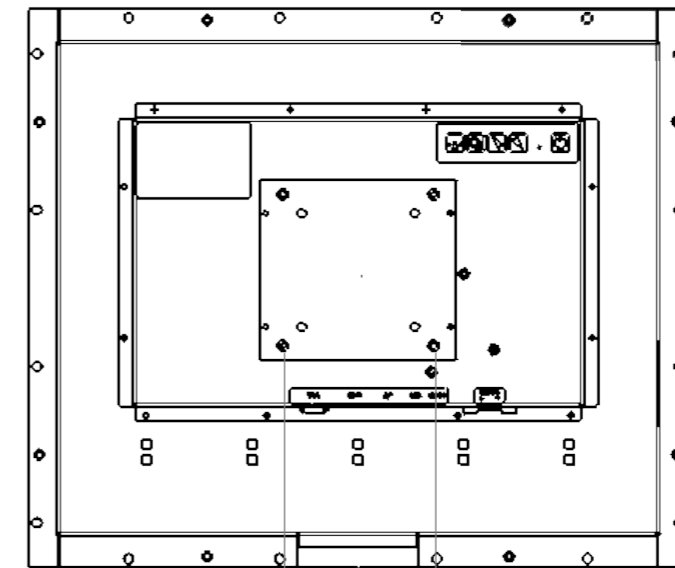
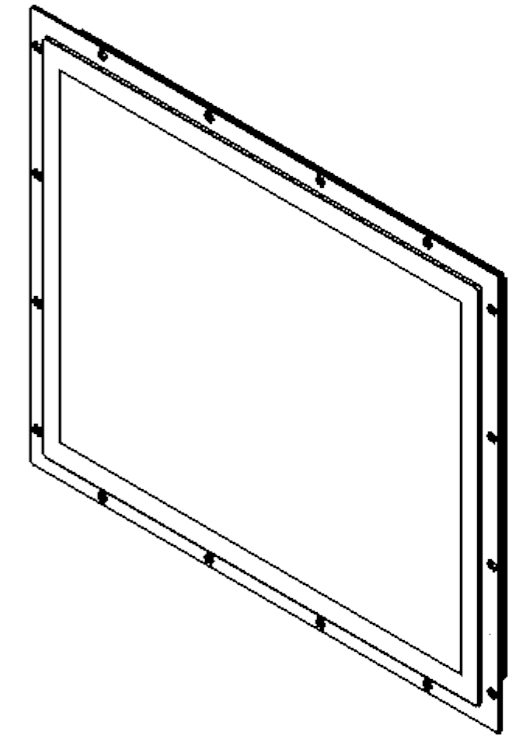
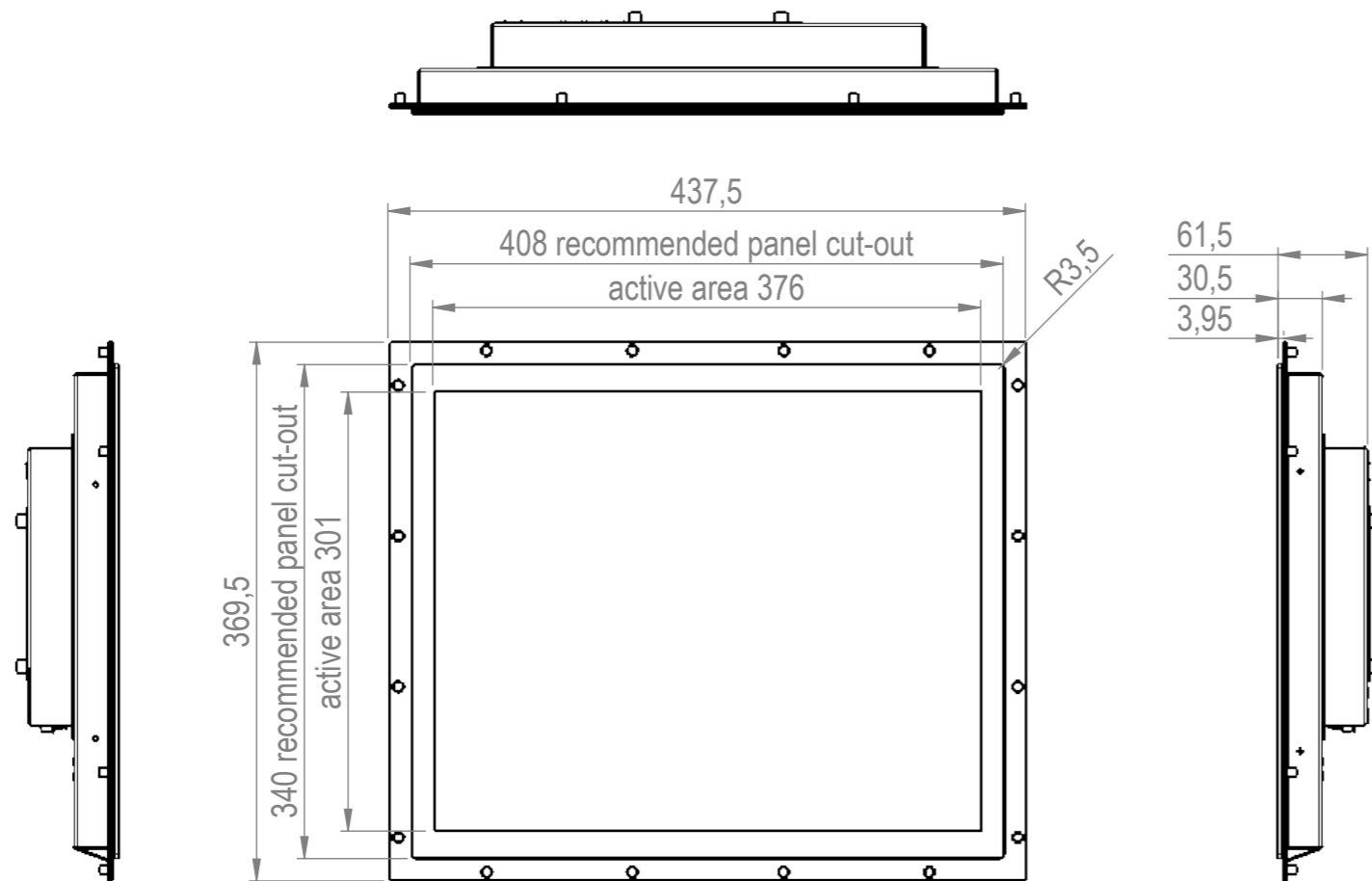

DATE		8-9-2023		DO NOT SCALE DRAWING		DIMENSIONS ARE IN MM	
REV.	DRAWN	AdJ		<b>TFT/Solutions</b>			
1-01	APPROVED	AdJ					
MATERIAL				DESCRIPTION			
				Assembly			
FINISH				PAGE NAME			
				P190-MON			
				DWG NO.			
				P190-00			
				SCALE:1:5		SHEET 3 OF 4	
						A3	

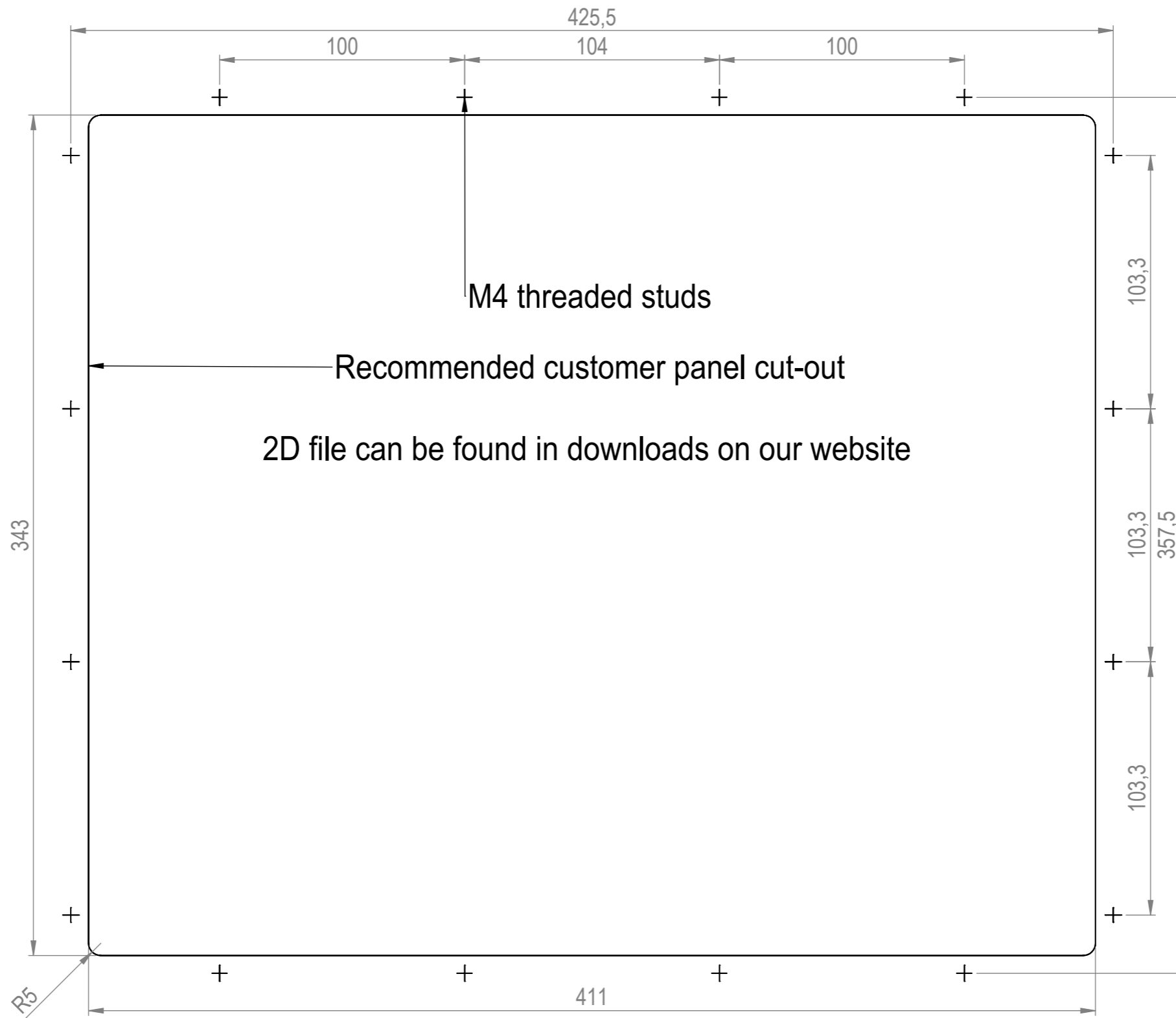

DATE		8-9-2023		DO NOT SCALE DRAWING		DIMENSIONS ARE IN MM	
REV.	DRAWN	AdJ		<b>TFT/Solutions</b>			
1-01	APPROVED	AdJ					
MATERIAL				DESCRIPTION Assembly			
FINISH				PAGE NAME Mounting guide			
				DWG NO. P190-00			
				SCALE:1:2		SHEET 4 OF 4	
						A3	